

CARBURETOR SERVICE PROCEDURE HOLLEY 2-BARREL MODEL 2300, 2300-C, 2300-G, 2300-MG & 2300-EG

FORM NO.
16H-26-861

NOTE: Some models of the Holley 2300 series carburetors may vary in general design and appearance, but basic cleaning and adjustment procedures will remain the same.

1. DISASSEMBLY

Using the exploded view as a guide, disassemble carburetor only enough to permit a thorough cleaning. Pay particular attention to the following:

- Do not disassemble the fuel inlet needle and seat assembly. They are a matched set and are serviced as an assembly.
- Removal of choke or throttle valves is not necessary unless part is bent, seized or damaged, requiring repair or replacement. If removal is necessary, file staked (peened) end of valve retaining screws prior to removal.
- Some models will be equipped with a plastic block (volume reducers) in the float bowl and the metering body. These blocks are part of the evaporative emission system. Make sure blocks are removed if carburetor is thoroughly cleaned.

NOTE: If limiter caps are removed, the carburetor must be recalibrated with required equipment to meet state and federal exhaust emission regulations. Remove limiter caps. Record number of turns required to seat idle mixture screws and retain for reassembly. Remove screws.

NOTE: On 1983 and later California models, drill a 3/32" hole in taper proof plugs. Use an easy-out to remove plug.

2. CLEANING

- Using a regular cleaning solution, soak parts long enough to thoroughly clean all surfaces and passages of foreign matter.
- Do not soak parts containing rubber, leather or plastic, except limiter caps.
- To remove any residue after use of cleaner, rinse parts in a suitable solvent.
- Blow out all passages with dry compressed air.

3. REASSEMBLY

Reassemble carburetor in reverse order of disassembly, paying particular attention to the following:

- Accelerator pump discharge needle is installed with tip down. If check ball and weight are used in place of needle, place weight on top of ball.
- Press idle mixture seals into recessed area of metering body before installing idle mixture screws. Do not attempt to slide seals over mixture screws. (This does not apply to some governed models having idle mixture screws located in the throttle body).
- When installing the accelerator pump diaphragm, make sure that the raised boss on the hub is facing lever in pump cover.
- On 2300-C models, make sure projection on the choke rod is positioned under the fast idle cam. This ensures that the fast idle cam will be raised up when the choke valve is closed.
- On 2300-G, 2300-MG and 2300-EG models, make sure pin on fast idle cam is positioned between the 2 tangs on the choke rod lever when the fast idle cam housing is installed.
- Apply petroleum jelly to all "O" rings before installation.
- After accelerator pump discharge nozzle has been installed, lightly stake nozzle against edge of screw with a punch to secure in position.
- Some late model carburetors will be equipped with a pump transfer tube in metering body. The metering body-to-main body gasket used on models with a pump transfer tube differs slightly from models without a pump transfer tube. These gaskets are not interchangeable. See Fig. 1.

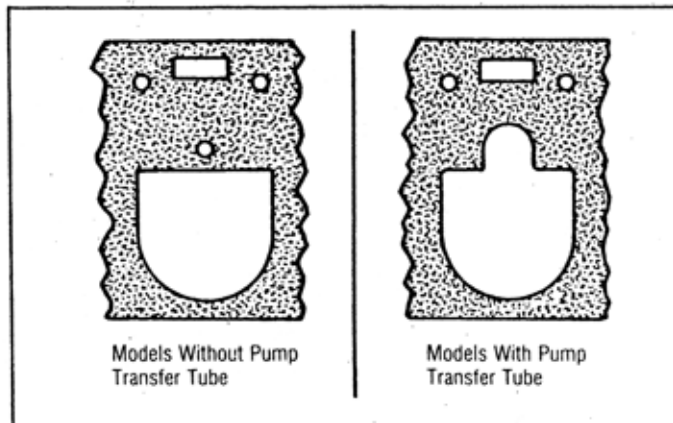

Fig. 1 Metering Body Gasket Identification

4. ADJUSTMENTS

A. Float Level (Dry Setting)

TYPE A

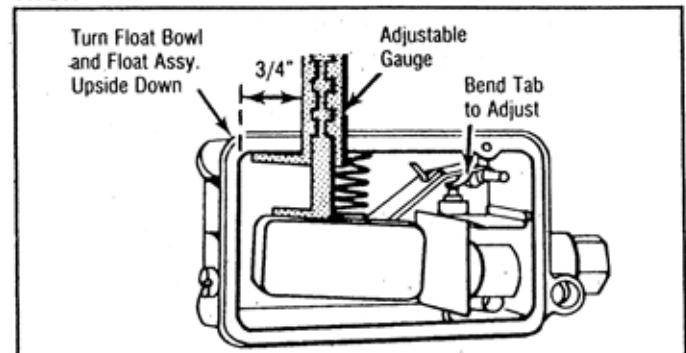

Fig. 2 Float Level Adjustment - Dry Setting
(Type A - If Equipped)

1. Assemble gauge included in kit. Calibrate to scale "A". Remove float bowl and turn upside down, allowing float to close fuel inlet needle valve. See Fig. 2.
2. With gauge positioned 3/4" away from vertical side of float bowl, measure the distance between the float and the bowl surface directly above the float.
3. To adjust, bend tab on float arm.

TYPE B

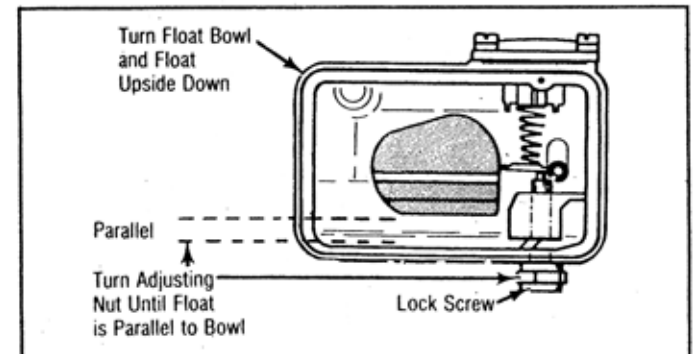

Fig. 3 Float Level Adjustment - Dry Setting
(Type B - If Equipped)

1. Remove float bowl and turn upside down. Top of float should be parallel with float bowl. See Fig. 3.
2. To adjust, loosen lock screw and turn adjusting nut until float is parallel with float bowl.

TYPE C

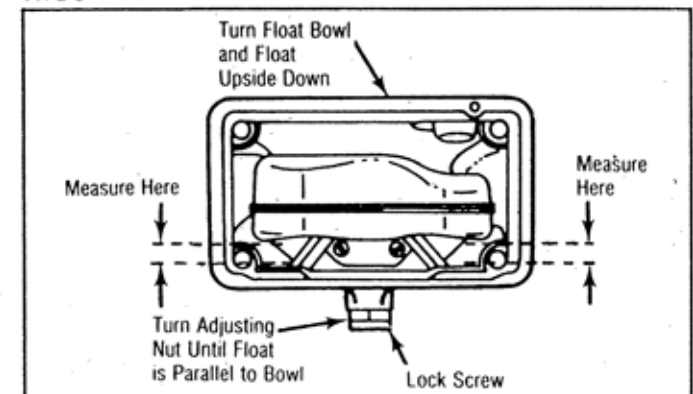

Fig. 4 Float Level Adjustment - Dry Setting
(Type C - If Equipped)

1. Remove and invert float bowl. Float should rest on fuel inlet needle, equidistant from top and bottom of inside surface of float bowl. See Fig. 4.

NOTE: On some models a specified dimension will be given in specification table. Check specified dimension at both ends of float. This ensures that float will be parallel.

2. To adjust, loosen lock screw and turn adjusting nut until float is parallel and centered in the float bowl. It may be necessary to carefully twist the float arm to make sure float is parallel in float bowl.

B. Accelerator Pump

ACCELERATOR PUMP INLET CHECK BALL CLEARANCE
(MODELS WITH CHECK BALL RETAINER BAR ONLY)

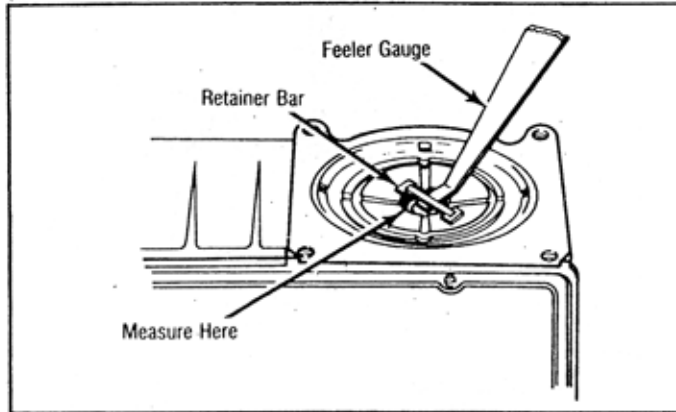

Fig. 5 Accelerator Pump Inlet Check Ball Clearance (Models With Check Ball Retainer Bar Only)

1. Remove float bowl and turn upside down. Measure specified clearance between check ball and retainer bar with a feeler gauge. Specified clearance for all models is .015". See Fig. 5.
2. To adjust, carefully bend retainer bar. Extreme care must be taken to prevent damage to ball, seat or retainer bar.

ACCELERATOR PUMP STROKE

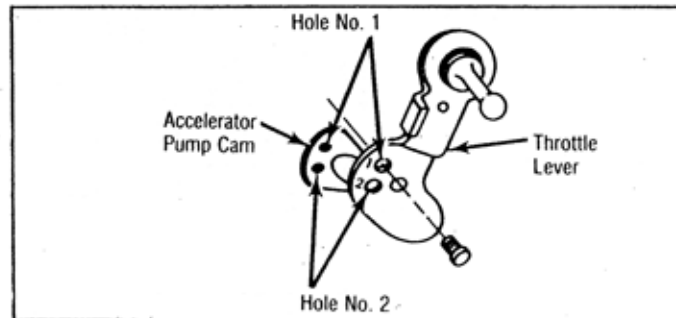

Fig. 6 Accelerator Pump Stroke Adjustment

NOTE: The position of the accelerator pump cam controls the accelerator pump stroke. The cam is preset at the factory. Adjustments should be made only if original setting has been changed.

1. Check accelerator pump cam to ensure cam retaining screw is positioned in specified hole in throttle lever. See Fig. 6.
2. Upper hole in throttle lever is hole number 1 and lower hole is number 2. On some models, these numbers may be stamped on the throttle lever.

ACCELERATOR PUMP LEVER CLEARANCE

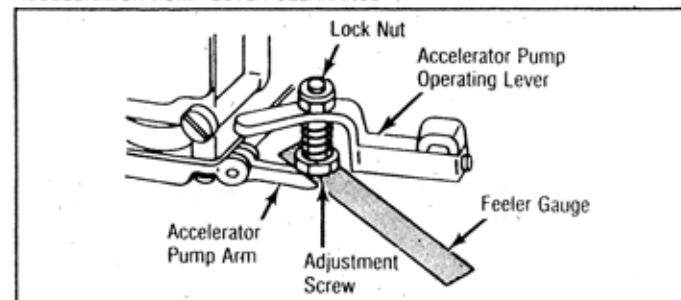

Fig. 7 Accelerator Pump Lever Clearance Adjustment

1. Hold throttle valves wide open. Manually depress accelerator pump arm. See Fig. 7.

2. Using a feeler gauge, measure accelerator pump lever clearance between adjustment screw head and accelerator pump arm. Specified clearance on all models is .015".
3. To adjust, loosen adjustment screw lock nut. Turn adjusting screw in to increase clearance and out to decrease clearance. Tighten lock nut.

C. Bowl Vent Valve

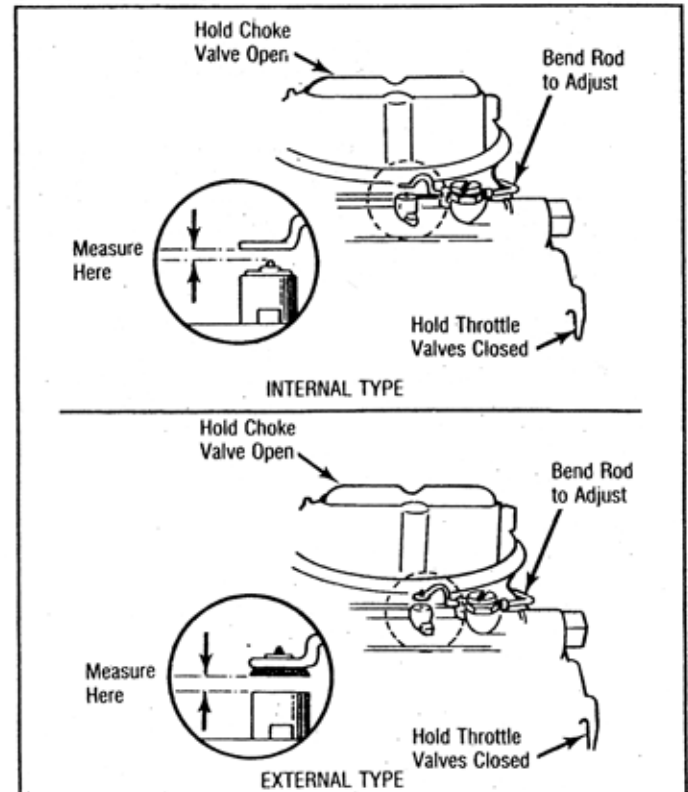

Fig. 8 Bowl Vent Valve Adjustment

1. Hold choke valve wide open. Close throttle valves, making sure throttle lever is against stop screw. See Fig. 8.
2. Using a feeler gauge, measure bowl vent valve specified clearance between valve stem and actuator rod (models with internal type vent valve) or between rubber valve and seat on main body (models with external type vent valve).

NOTE: If specified clearance is not given in specification table, adjust internal type to .015" clearance and adjust external type to .060" clearance.

3. To adjust, bend actuating rod at a point close to actuating lever on throttle linkage.

D. Choke Pull Down

EXTERNAL VACUUM DIAPHRAGM TYPE

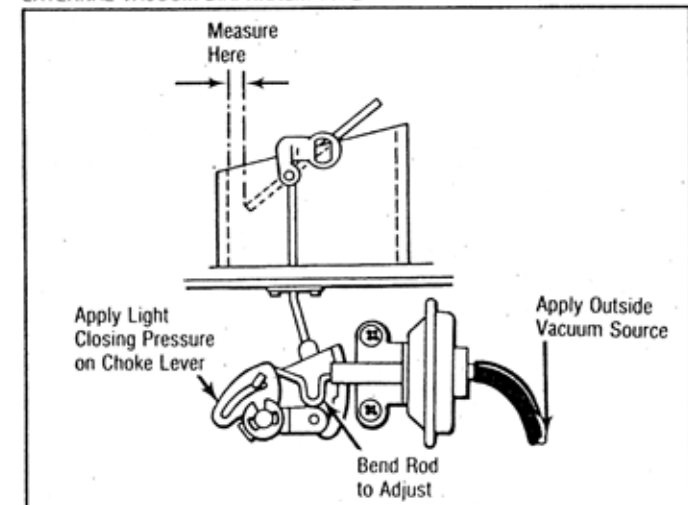

Fig. 9 Choke Pull Down Adjustment (External Vacuum Diaphragm Type)

1. Position fast idle tang on second highest step of fast idle cam. Seat vacuum diaphragm by applying a vacuum source of at least 15 in. Hg. See Fig. 9.
2. Close choke as far as possible by applying a light closing pressure on choke lever.
3. Measure choke pull down specified clearance between lower edge of choke valve and air horn wall.
4. To adjust, bend choke rod between lever and vacuum diaphragm.

EARLY INTEGRAL PISTON TYPE

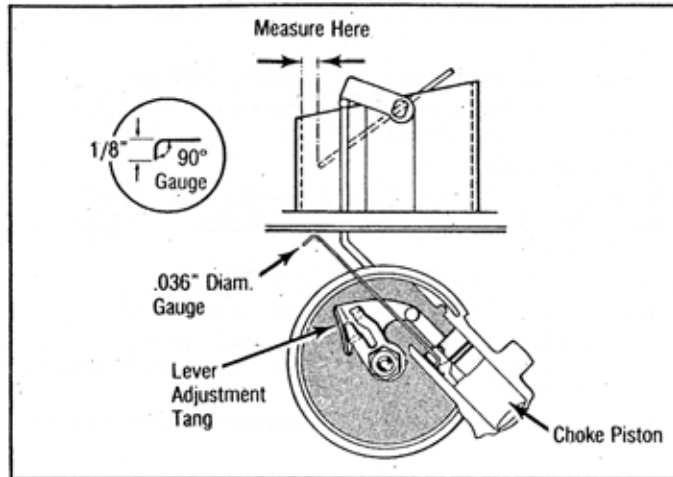

Fig. 10 Choke Pull Down Adjustment (Early Integral Piston Type)

1. With choke coil housing and baffle plate removed, insert a .036" diameter wire gauge into the piston bore until it hooks into the relief in piston bore. See Fig. 10.

NOTE: A gauge can be constructed from a paper clip if necessary. Construct the gauge to the dimensions shown in Fig. 10.

2. Rotate choke piston lever counterclockwise until gauge is in piston slot. Measure choke pull down specified clearance between lower edge of choke valve and air horn wall.
3. To adjust, bend the piston lever adjustment tang.

LATE INTEGRAL PISTON TYPE

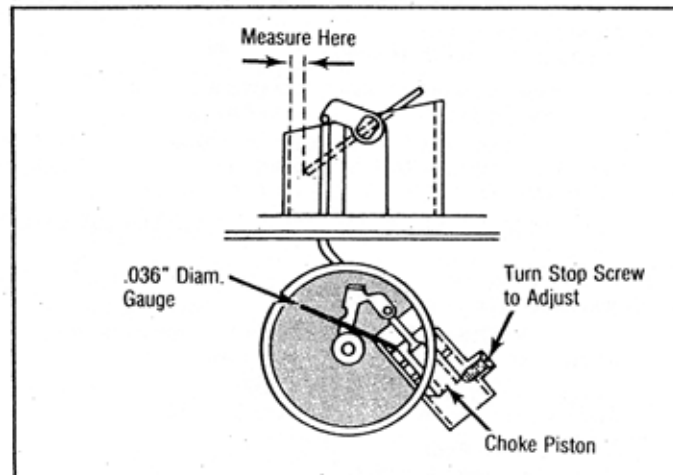

Fig. 11 Choke Pull Down Adjustment (Late Integral Piston Type)

1. With choke coil housing and baffle plate removed, insert a .036" wire gauge into the piston bore. This will move piston down against stop. See Fig. 11.
2. Hold choke valve toward closed position. Measure choke pull down specified clearance between lower edge of choke valve and air horn wall.
3. To adjust, remove putty covering stop screw. Turn stop screw clockwise to decrease clearance or counterclockwise to increase clearance.

E. Fast Idle Cam

REMOTE CHOKE MODELS

1. Position fast idle adjusting tang on the second highest step of the fast idle cam. Move choke valve toward the closed position with light pressure on the choke lever. See Fig. 12.

2. Measure specified clearance between the upper edge of the choke valve and the air horn wall.
3. To adjust, bend the choke lever tang until the correct choke valve opening dimension has been obtained.

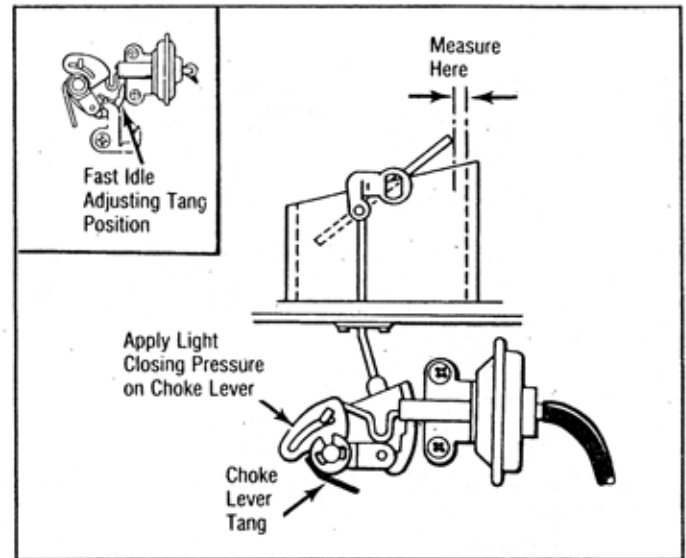

Fig. 12 Fast Idle Cam Adjustment (Remote Choke Models)

INTEGRAL CHOKE MODELS

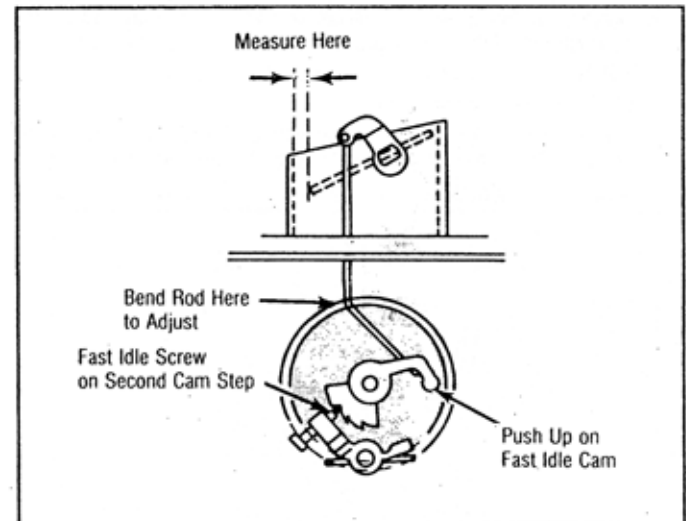

Fig. 13 Fast Idle Cam Adjustment (Integral Choke Models)

1. Loosen choke thermostat cover screws. Rotate cover 45° counterclockwise (rich) to close choke valve. Tighten choke cover screws. See Fig. 13.
2. Open and close throttle to position fast idle speed screw on highest (top) step of fast idle cam.
3. Insert a specified gauge between lower edge of choke valve and air horn wall. Open and close throttle to allow fast idle cam to drop.
4. Press up on fast idle cam. There should be little or no movement, indicating that the fast idle speed screw is on the second highest (kickdown) step of the fast idle cam, against the shoulder of the highest (top) step of cam.
5. To adjust, bend choke control rod until the fast idle speed screw is in the correct position on the fast idle cam. Readjust the thermostatic choke cover to specified setting.

F. Choke Unloader

1. Hold throttle valves wide open. Apply light closing pressure on choke valve. See Fig. 14.
2. Measure choke unloader specified clearance between lower edge of choke valve and air horn wall (integral choke models) or between upper edge of choke valve and air horn wall (remote choke models).
3. To adjust, bend pawl on fast idle lever (integral choke models) or tang on throttle lever (remote choke models).

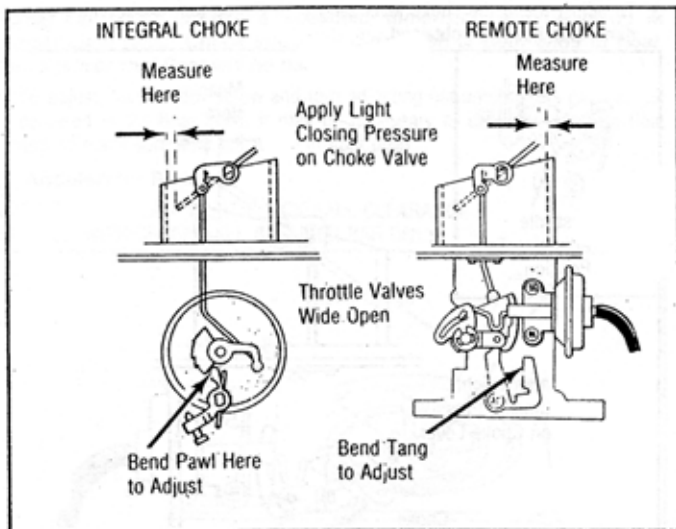

Fig. 14 Choke Unloader Adjustment

G. Automatic Choke

REMOTE CHOKE MODELS

1. Loosen lock nut. Using a screwdriver, turn assembly until mark on disc is aligned with specified mark on housing.
2. Tighten lock nut. Choke valve should be closed completely and be free to open with light finger pressure.

INTEGRAL CHOKE MODELS

1. Loosen 3 choke thermostat cover screws.
2. Rotate cover in "Rich" or "Lean" direction to align reference mark on cover with specified graduation on choke housing. Tighten cover screws.

H. Fuel Level (Wet Setting)

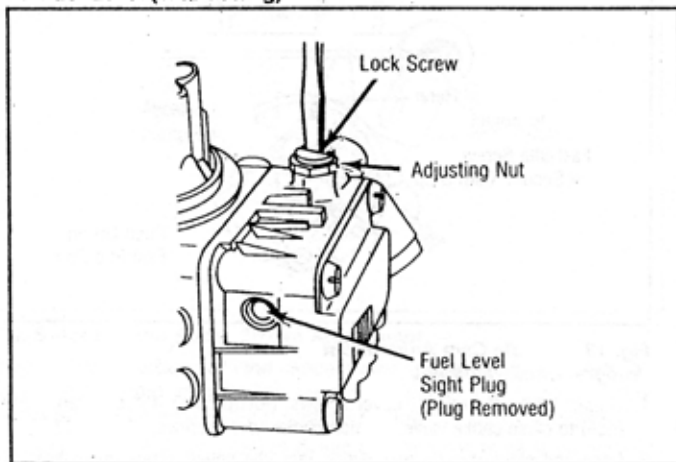

Fig. 15 Fuel Level Adjustment (Wet Setting)

1. Position vehicle on a level surface. Start engine and warm to normal operating temperature to stabilize fuel level.
2. Stop engine and remove sight plug from primary float bowl. Fuel level should be even with base of sight plug hole (plus or minus 1/32"). See Fig. 15.
3. If fuel level is incorrect, loosen lock screw only enough to allow rotation of adjusting nut. Turning adjusting nut clockwise will lower fuel level and turning nut counterclockwise will raise fuel level. Turning nut 1/8 turn will change fuel level approximately 1/16".
4. After each adjustment, tighten lock screw and install sight plug. Start engine to stabilize fuel level again. Stop engine and recheck fuel level.

I. Fast Idle Speed

NOTE: Refer to engine compartment decal for correct procedure and specifications. If no decal is present, proceed as follows:

On all Ford models, disconnect and plug vacuum hose to EGR and canister purge hose (if equipped).

TYPE A

1. Place fast idle screw on low step of fast idle cam.

2. Adjust fast idle screw to specified clearance, given in specification table. Measure specified clearance between fast idle screw and fast idle cam. Fractions, where given, are the number of turns to back fast idle screw off from the low step of the fast idle cam.

TYPE B

1. Place fast idle cam follower on the highest (top) step of fast idle cam.
2. Turn fast idle adjusting screw to obtain specified fast idle RPM.

TYPE C

1. Place fast idle lever tang on second highest step of fast idle cam.
2. To adjust to specified fast idle speed, insert a screwdriver into the slot in the lever tang and rotate tang to the left or right as required.

J. Curb Idle Speed

NOTE: If idle limiter caps have been removed, refer to Manufacturer's Service Manual for correct idle mixture procedure and specifications (air/fuel ratio).

ALL MODELS EXCEPT 1983 AND LATER FORD TRUCKS

1. Warm engine to operating temperature. Open choke valve fully.
2. With idle stop solenoid energized (if equipped) and air cleaner installed, set idle speed RPM as shown on the engine compartment Emission Control Tune-Up Decal by turning curb idle adjusting screw.
3. Adjust idle mixture screws to obtain smoothest idle within range of limiter caps.
4. Readjust curb idle speed screw as necessary.

1983 AND LATER FORD TRUCKS

1. Warm engine to operating temperature, remove air cleaner, place transmission in Neutral and set parking brake.
2. Disconnect and plug vacuum hose from decel throttle control kicker. Connect a slave vacuum hose from engine intake manifold to kicker.
3. Run engine at 2500 RPM for 15 seconds. Release throttle. Decel throttle control kicker RPM must be within 50 RPM of specification. Disconnect slave vacuum hose and allow engine to return to curb idle.
4. Adjust curb idle if necessary by adjusting the curb idle screw. Momentarily accelerate engine and allow to return to idle. Check and adjust curb idle speed if necessary.
5. Reconnect throttle control vacuum hose to diaphragm. Reinstall air cleaner.

K. Throttle Closing Rods (Triple Carburetor Installation)

1. Warm engine to normal operating temperature. Turn off ignition. Open choke valve fully and hold all throttle valves fully closed.
2. Disconnect closing rods from secondary (front & rear) carburetor throttle levers. Clevis pin must be fully bottomed in primary (center) carburetor throttle lever slot.
3. Adjust closing rods so they just enter hole in the secondary carburetor throttle levers.

NOTE: On Corvettes, adjust rear closing rod so end of rod is 1/2 rod diameter short of hole in throttle lever.

4. Adjust length of rods by turning them in or out of threaded sleeves attached to clevis pins.
5. Reconnect closing rods to secondary carburetor throttle levers. Clevis pin should be just above slot in primary carburetor throttle lever.

L. Choke Control Rods (Triple Carburetor Installation)

NOTE: Make this adjustment before making fast idle cam, choke pull down and choke unloader adjustments.

1. Open throttle valves to a half-open position and close choke valve by applying light pressure on choke control lever.
2. With carburetors mounted on engine, distance from top of choke rod hole in choke control lever to choke assembly should be $2-3/4 \pm 1/64$ ". With carburetor on bench, distance from top of choke rod hole in choke control lever to base of carburetor should be $1-17/32 \pm 1/64$ ".
3. To adjust, bend choke lever rod at offset in rod. Test for free movement of choke valve.

M. Dashpot

1. Warm engine to normal operating temperature and run at normal idle speed.
2. Fully depress dashpot stem. Measure specified clearance between end of stem and throttle lever. Specified clearance on all models, is .070-.090".
3. To adjust, loosen lock nut and rotate dashpot. Tighten lock nut.